



SPECIFICATIONS

CUSTOMER : MANSEI

SAMPLE CODE : _____

(This Code will be changed while mass production)

MASS PRODUCTION CODE : PG12864WRM-KNN-IL3
(VER:B)

Customer Approved

Date:

Sales Sign	QC Confirmed	Checked By	Designer
		<i>newell</i> 4/22 <i>Tom</i> 4/22	<i>青</i> 4/22

Approval For Specifications Only.

* This specification is subject to change without notice.

Please contact Powertip or it's representative before designing your product based on this specification.

Approval For Specifications and Sample.

Powertip Corporation

Headquarters:

No.8, 6th Road, Taichung Industrial Park,

Taichung, Taiwan

台中市 407 工業區六路 8 號

LCD Division:

TEL: 886-4-2355-6888

FAX: 886-4-2355-6898

E-mail: sales@display.powertip.com.tw

[Http://www.powertip.com.tw](http://www.powertip.com.tw)

LCM Division:

TEL: 886-4-2355-8168

FAX: 886-4-2355-8166

E-mail: sales@mail.powertip.com.tw

[Http://www.powertip.com.tw](http://www.powertip.com.tw)

RECORDS OF REVISION

Date	Rev.	Description	Note	Page
2003/4/20	0	Revised Contents		
2003/6/27	A	Update 1.1 Features LCD TYPE Normal Temp → Extended Temp.		4
2003/6/28	B	Update 1.1 Features LCD TYPE Positive → negative		4

Total : 20 Page

Contents

1. SPECIFICATIONS

- 1.1 Features
- 1.2 Mechanical Specifications
- 1.3 Absolute Maximum Ratings
- 1.4 DC Electrical Characteristics
- 1.5 Optical Characteristics
- 1.6 Backlight Characteristics

2. MODULE STRUCTURE

- 2.1 Counter Drawing
- 2.2 Interface Pin Description
- 2.3 Timing Characteristics
- 2.4 Display Command

3. QUALITY ASSURANCE SYSTEM

- 3.1 Quality Assurance Flow Chart
- 3.2 Inspection Specification

4. RELIABILITY TEST

- 4.1 Reliability Test Condition

5. PRECAUTION RELATING PRODUCT HANDLING

- 5.1 Safety
- 5.2 Handling
- 5.3 Storage
- 5.4 Terms of Warranty

Note : For detailed information please refer to IC data sheet : KS0107B, KS0108B

1. SPECIFICATIONS

1.1 Features

Item	Standard Value
Display Type	128*64 dots
LCD Type	STN, BLUE, Transmissive , Negative , Extended Temp.
Driver Condition	LCD Module : 1/64 Duty , 1/8.5 Bias
Viewing Direction	6 O' clock
Backlight	White LED B/L
Weight	70g
Interface	-
Other(controller/driver IC)	-

1.2 Mechanical Specifications

Item	Standard Value	Unit
Outline Dimension	93.0(L) * 70.0(w) * 14.0(H)(Max)	mm
Viewing Area	72.0(L) * 40.0(w)	mm
Active Area	66.52(L) * 33.24(w)	mm
Dot Size	0.48(L) * 0.48(w)	mm
Dot Pitch	0.52(L) * 0.52(w)	mm

Note : For detailed information please refer to LCM drawing

1.3 Absolute Maximum Ratings

Item	Symbol	Condition	Min.	Max.	Unit
Power Supply Voltage	V_{DD}	-	-0.3	7.0	V
LCD Driver Supply Voltage	$V_{DD}-V_{EE}$	-	$V_{DD}-19.0$	$V_{DD}+0.3$	V
Input Voltage	V_{IN}	-	-0.3	$V_{DD}+0.3$	V
Operating Temperature	T_{OP}	Excluded B/L	-20	70	
Storage Temperature	T_{ST}	Excluded B/L	-30	80	
Storage Humidity	H_D	$T_a < 40$	-	90	%RH

1.4 DC Electrical Characteristics

$V_{DD} = 5.0 \text{ V} \pm 10\%$, $V_{SS} = 0\text{V}$, $T_a = 25$

Item	Symbol	Condition	Min.	Typ.	Max.	Unit
Logic Supply Voltage	V_{DD}	-	4.5	5.0	5.5	V
“H” Input Voltage	V_{IH}	-	$0.7 V_{DD}$	-	V_{DD}	V
“L” Input Voltage	V_{IL}	-	0	-	$0.3 V_{DD}$	V
“H” Output Voltage	V_{OH}	-	2.4	-	-	V
“L” Output Voltage	V_{OL}	-	-	-	0.4	V
Supply Current	I_{DD}	$V_{DD} = 5.0 \text{ V}$	-	1.0	-	mA
LCM Driver Voltage	V_{OP}	$V_{DD} - V_O (-20^\circ\text{C})$	-	-	-	V
		$V_{DD} - V_O (25^\circ\text{C})$	-	12.6	-	
		$V_{DD} - V_O (70^\circ\text{C})$	-	-	-	

1.5 Optical Characteristics

LCD Panel : 1/64 Duty , 1/9 Bias , $V_{LCD} = 14 \text{ V}$, $T_a = 25$

Item	Symbol	Conditions	Min.	Typ.	Max.	Reference
View Angle	θ	$C \geq 2.0, \varnothing = 0^\circ$	40°	-	-	Notes 1 & 2
Contrast Ratio	C	$\theta = 5^\circ, \varnothing = 0^\circ$	5	7	-	Note 3
Response Time(rise)	t_r	$\theta = 5^\circ, \varnothing = 0^\circ$	-	150 ms	-	Note 4
Response Time(fall)	t_f	$\theta = 5^\circ, \varnothing = 0^\circ$	-	300 ms	-	Note 4

Note 1: Definition of angles θ and \varnothing

Light (when reflected) z ($\theta=0^\circ$)

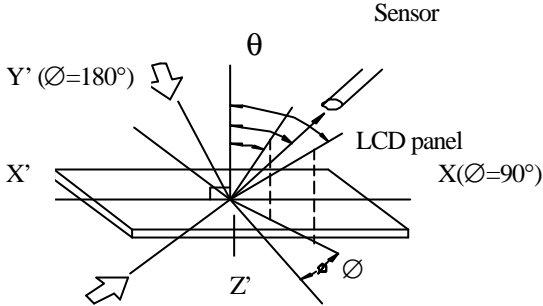

Light (when transmitted) Y ($\varnothing=0^\circ$)
($\theta=90^\circ$)

Note 2: Definition of viewing angles θ_1 and θ_2

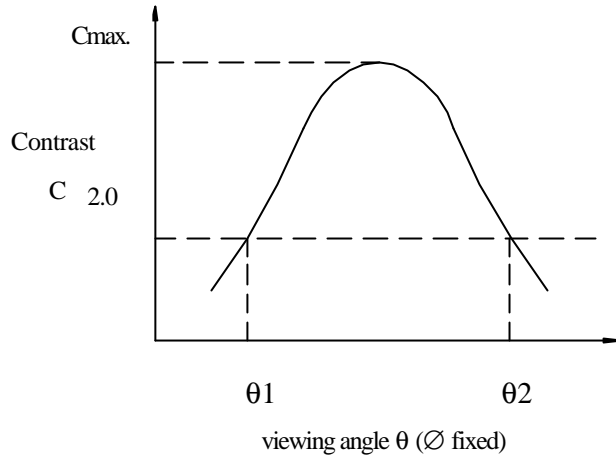

Note : Optimum viewing angle with the naked eye and viewing angle θ at C_{max} . Above are not always the same

Note 3: Definition of contrast C

$$C = \frac{\text{Brightness (reflection) of unselected dot (B2)}}{\text{Brightness (reflection) of selected dot (B1)}}$$

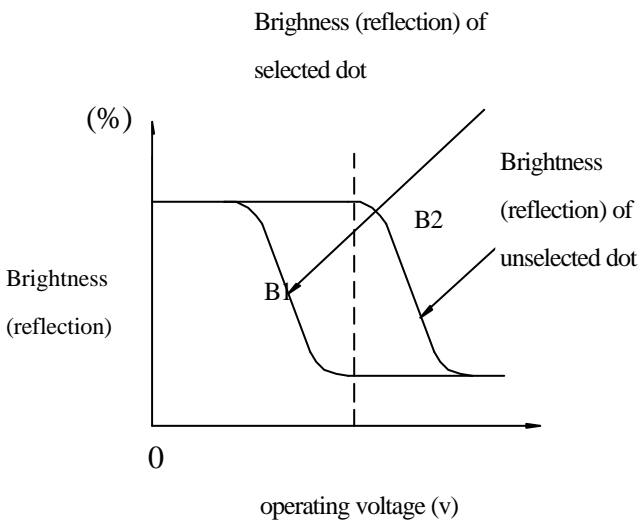

Note 4: Definition of response time

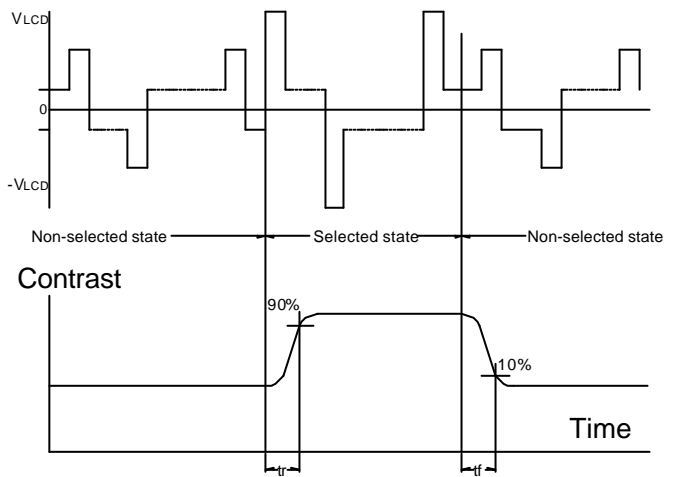

Note: Measured with a transmissive LCD panel which is displayed 1 cm^2

V_{LCD} : Operating voltage f_{FRM} : Frame frequency
 t_r : Response time (rise) t_f : Response time (fall)

1.6 Backlight Characteristics

LCD Module with LED Backlight

Maximum Ratings

Item	Symbol	Conditions	Min.	Max.	Unit
Forward Current	IF	Ta =25°C	-	72	mA
Reverse Voltage	VR	Ta =25°C	-	5	V
Power Dissipation	PO	Ta =25°C	-	0.29	W
Operating Temperature	T _{OP}	-	-20	70	
Storage Temperature	T _{ST}	-	-30	80	
Solder Temp. for 3 Second	-	-	-	260	

Electrical / Optical Characteristics

Ta =25

Item	Symbol	Conditions	Min.	Typ.	Max.	Unit
Forward Voltage	V _F	I _F =60 mA	3	3.3	4.0	V
Reverse Current	I _R	V _R =5V	-	-	0.15	mA
Average Brightness (with LCD)	I _V	I _F =60mA	-	-	-	cd/m ²
Average Brightness (without LCD)	I _V	I _F =60 mA	160	245	-	
Wavelength	λ	I _F =60 mA	-	White	-	nm
Color	White					

2. MODULE STRUCTURE

2.1 Counter Drawing

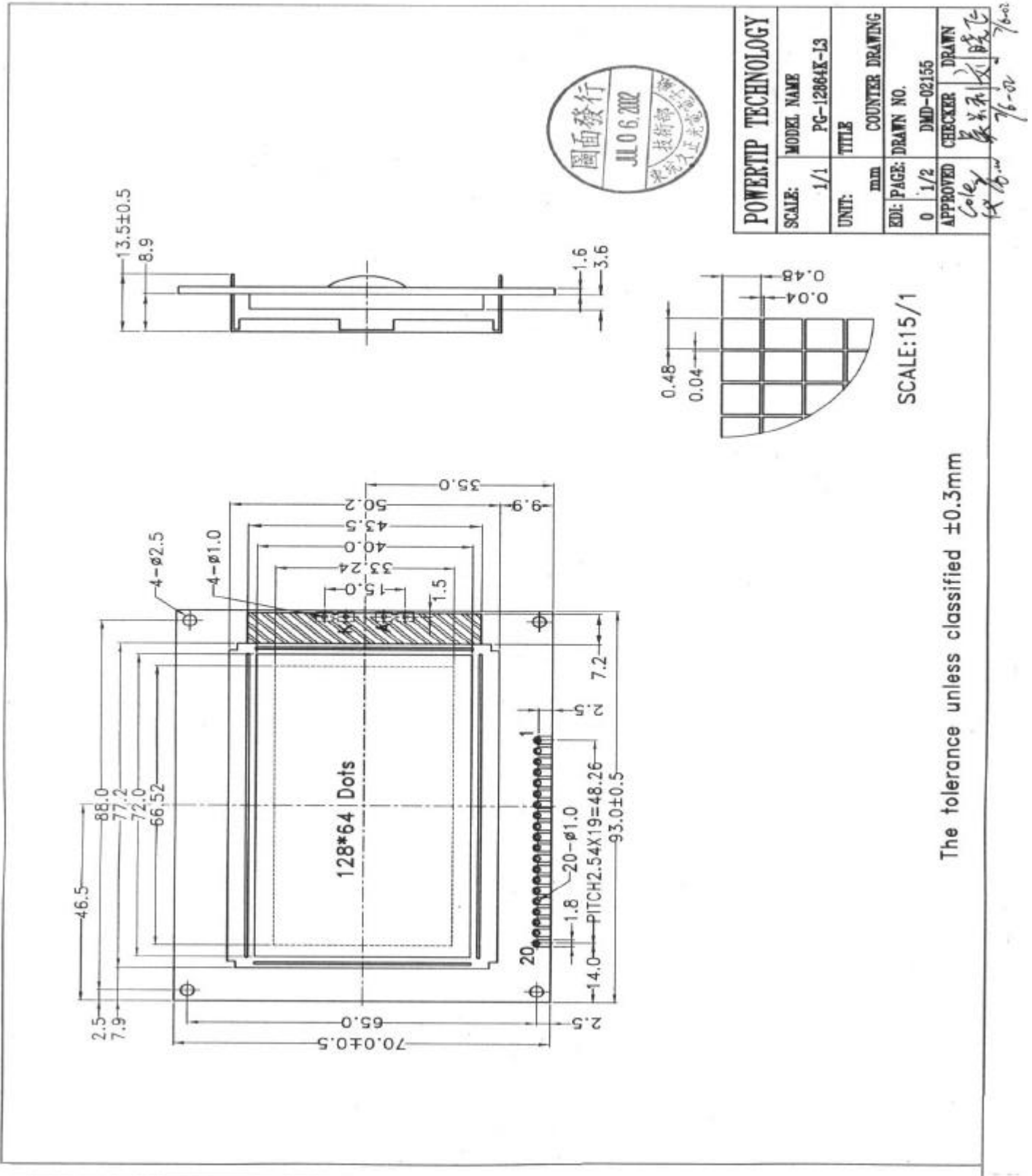

PIN NO.	SIGNAL
1	Vss
2	Vdd
3	Vo
4	D/I
5	R/W
6	E
7	DB0
8	DB1
9	DB2
10	DB3
11	DB4
12	DB5
13	DB6
14	DB7
15	CS1
16	CS2
17	RST
18	Vout
19	A
20	K

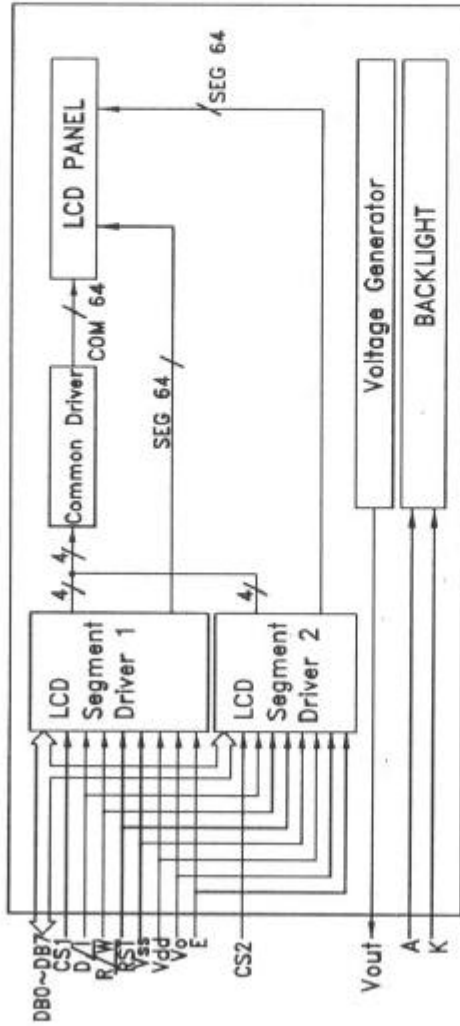

POWERTIP TECHNOLOGY		
SCALE:	MODEL NAME	
NO SCALE	PG-12864K-LS	
UNIT:	TITLE	
NO UNIT	COUNTER DRAWING	
EDI: PAGE:	DRAWN NO.	
0 2/2	DMD-02155	
APPROVED	CHECKER	DRAWN
曹	曹	曹

7/6-02 7/6-02

2.2 Interface Pin Description

Pin No.	Symbol	Function
1	VSS	Signal ground (GND)
2	VDD	Power supply for logic (VDD > VSS)
3	V _o	Operating voltage for LCD (variable)
4	D/ $\overline{\text{I}}$	Register selection input High =Data register Low =Instruction register (for write) Busy flag address counter (for read)
5	R/ $\overline{\text{W}}$	$\overline{\text{R/ W}}$ signal input is used to select the read/write mode High =Read mode, Low =Write mode
6	E	Start enable signal to read or write the data
7-14	DB0-DB7	Data bus
15	CS1	Chip enable for D2 (segment 1 to segment 64)
16	CS2	Chip enable for D3 (segment 65 to segment 128)
17	$\overline{\text{RST}}$	Reset signal
18	V _{out}	Negative voltage power supply
19	A	Power supply for LED backlight (+)
20	K	Power supply for LED backlight (-)

Contrast Adjust

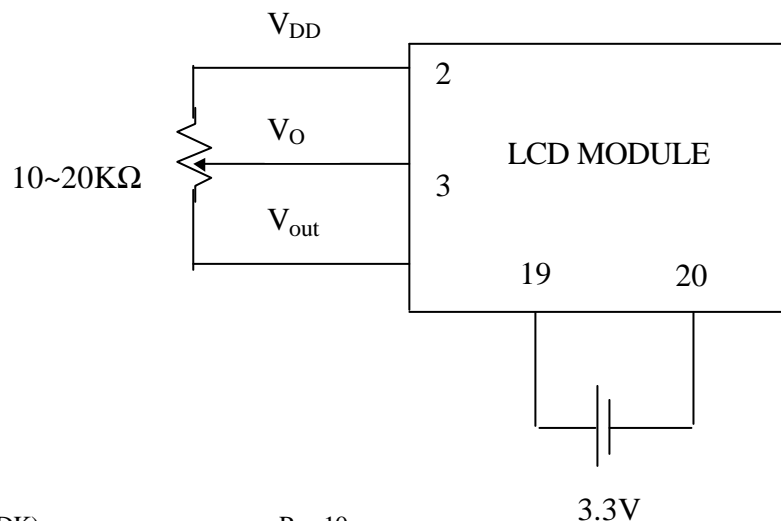

2.3 Timing Characteristics

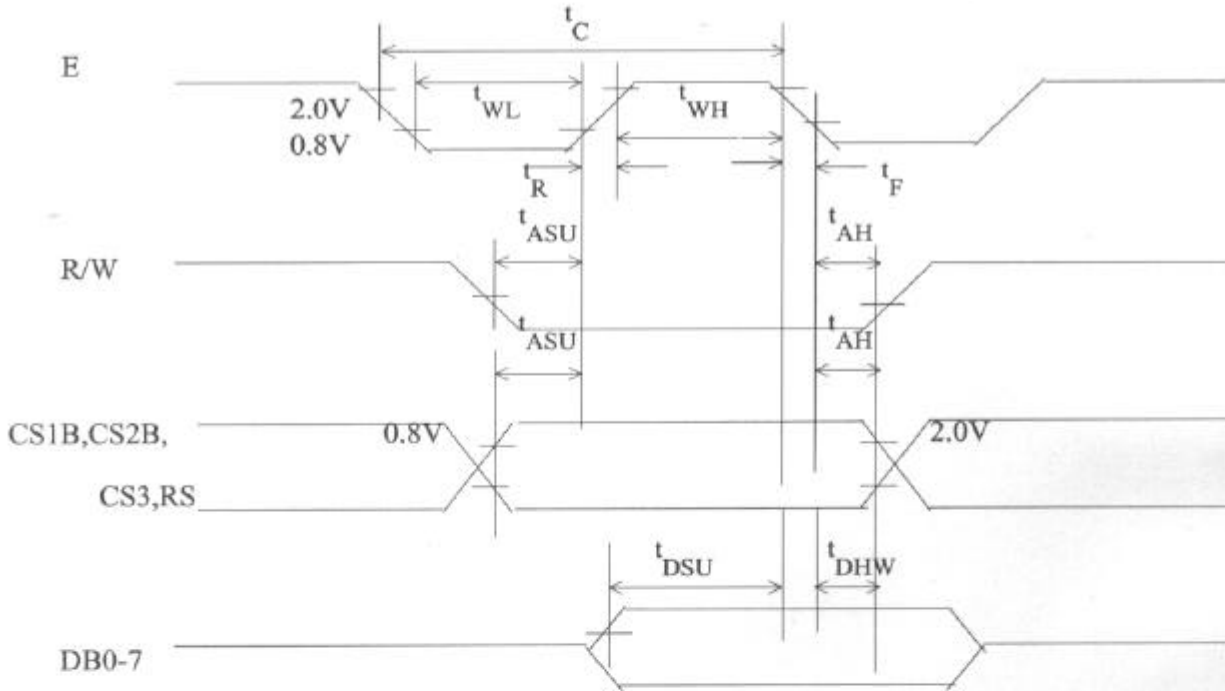

MPU write timing

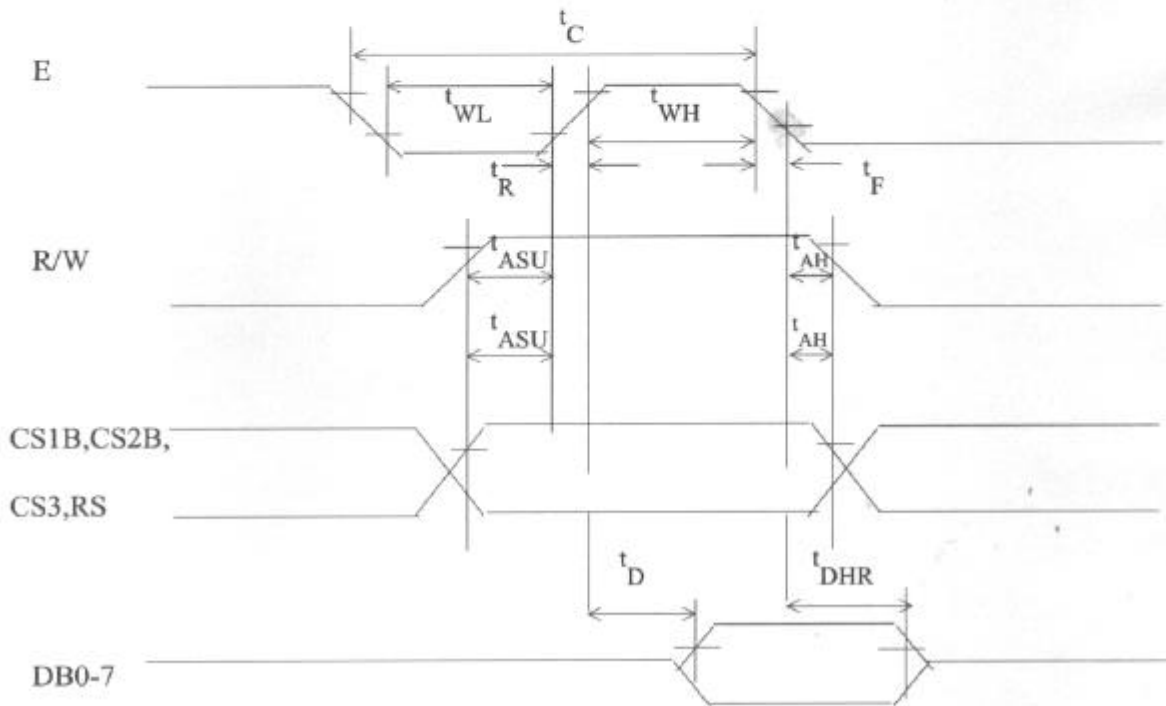

MPU read timing

Set DDRAM Address	0	0	1	AC	AC	AC	AC	AC	AC	AC	Set DDRAM address in address counter.	37 μ s
----------------------	---	---	---	----	----	----	----	----	----	----	--	------------

Characteristic	Symbol	Min.	Typ	Max	Unit
E Cycle	tC	1000	-	-	ns
E High Level Width	tWH	450	-	-	ns
E Low Level Width	tWL	450	-	-	ns
E Rise Time	tR	-	-	25	ns
E Fall Time	tF	-	-	25	ns
Address Set-Up time	tASU	140	-	-	ns
Address Hold Time	tAH	10	-	-	ns
Data Set-Up Time	tDSU	200		-	ns
Data Delay Time	tD	-	-	320	ns
Data Hold Time (Write)	tDHW	10	-	-	ns
Data Hold Time (Read)	tDHR	20	-	-	ns

2.4 Display command

Instructions	D/I	R/W	DB7	DB6	DB5	DB4	DB3	DB2	DB1	DB0	Functions	
Display on/off	L	L	L	L	H	H	H	H	H	L/H	Controls the display on or Off. Internal status and display RAM data is not affected. L: OFF , H: ON	
Set address (Y address)	L	L	L	H	Y address (0~63)						Sets the Y address in the Y address counter.	
Set Page (X address)	L	L	H	L	H	H	H	Page (0-7)			Sets the X address at the X register.	
Display Start Line (Z address)	L	L	H	H	Display start line (0~63)						Indicates the display data RAM displayed at the top of the screen.	
Status Read	L	H	B U S Y	L	O N / O F F	R E S E T	L	L	L	L	Reads status. BUSY H : In operation L : Ready ON/OFF H : Display OFF L : Display ON RESET H : Reset L : Normal	
Write Display Data	H	L	Write Data									Writes data (DB0:7) into display data RAM. After writing instruction, Y address is increased by 1 automatically.
Read Display Data	H	H	Read Data									Reads data (DB0:7) from display data RAM to the data bus.

Detailed Explanation

Display On/Off

	RS	R/W	DB7.....DB0							
Code	0	0	0	0	1	1	1	1	1	D

The display data appears when D is 1 and disappears when D is 0. Though the data is not on the screen with D=0, it remains in the display data RAM. Therefore, you can make it appear by changing D=0 into D=1.

Display Start Line (Z Address)

	RS	R/W	DB7.....DB0							
Code	0	0	1	1	AC5	AC4	AC3	AC2	AC1	AC0

Z address(AC0-AC2) of display data RAM is set in the display start line register and display at the top of the screen. When the display duty cycle is 1/64 or others(1/32-1/64), the data of total line number of LCD screen, from the line specified by display start line instruction, is displayed. See figure 1.

Set page (X address)

	RS	R/W	DB7.....DB0							
Code	0	0	1	0	1	1	1	AC2	AC1	AC0

X address (AC0-AC2) of the display data RAM is set in the X address register. Writing or reading to or from MPU is executed in this specified page until the next page is set. See figure 2.

Set Address (Y Address)

	RS	R/W	DB7.....DB0							
Code	0	0	0	1	AC5	AC4	AC3	AC2	AC1	AC0

Y address(AC0-AC5) of the display data RAM is set in the Y address Counter. An address is set by instruction and increased by 1 automatically by read or write operation of display data.

Status Read

	RS	R/W	DB7.....DB0							
Code	1	0	BUSY	0	ON/OFF	REST	0	0	0	0

- Busy

When busy is 1, the Chip is executing internal operation and no instructions are accepted

When busy is 0, the Chip is read to accept any instructions.

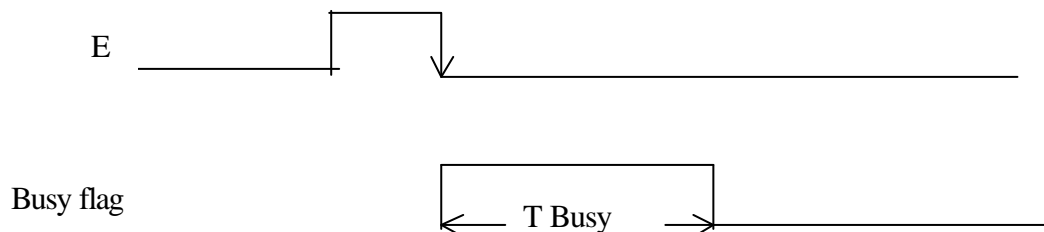

- ON/OFF

When on/off is 1, the display is OFF.

When on/off is 0, the display is ON.

1/fCLK T Busy 3/fCLK

- RESET

When RESET is 1, the system is being initialized.

In this condition, no instructions except status read can be accepted.

When RESET is 0,initializing has finished and the system is in the usual operation condition.

Write Display Data

	RS	R/W	DB7.....DB0							
Code	0	1	D7	D6	D5	D4	D3	D2	D1	D0

Write data(D0-D7)from the display data RAM.After writing instruction, Y address is increased by 1 automatically.

Read Display Data

	R/W	D/I	DB7.....DB0							
Code	1	1	D	D	D	D	D	D	D	D

Reads data(D0-D7) from the display data RAM. After reading instruction, Y address is increased by 1 automatically

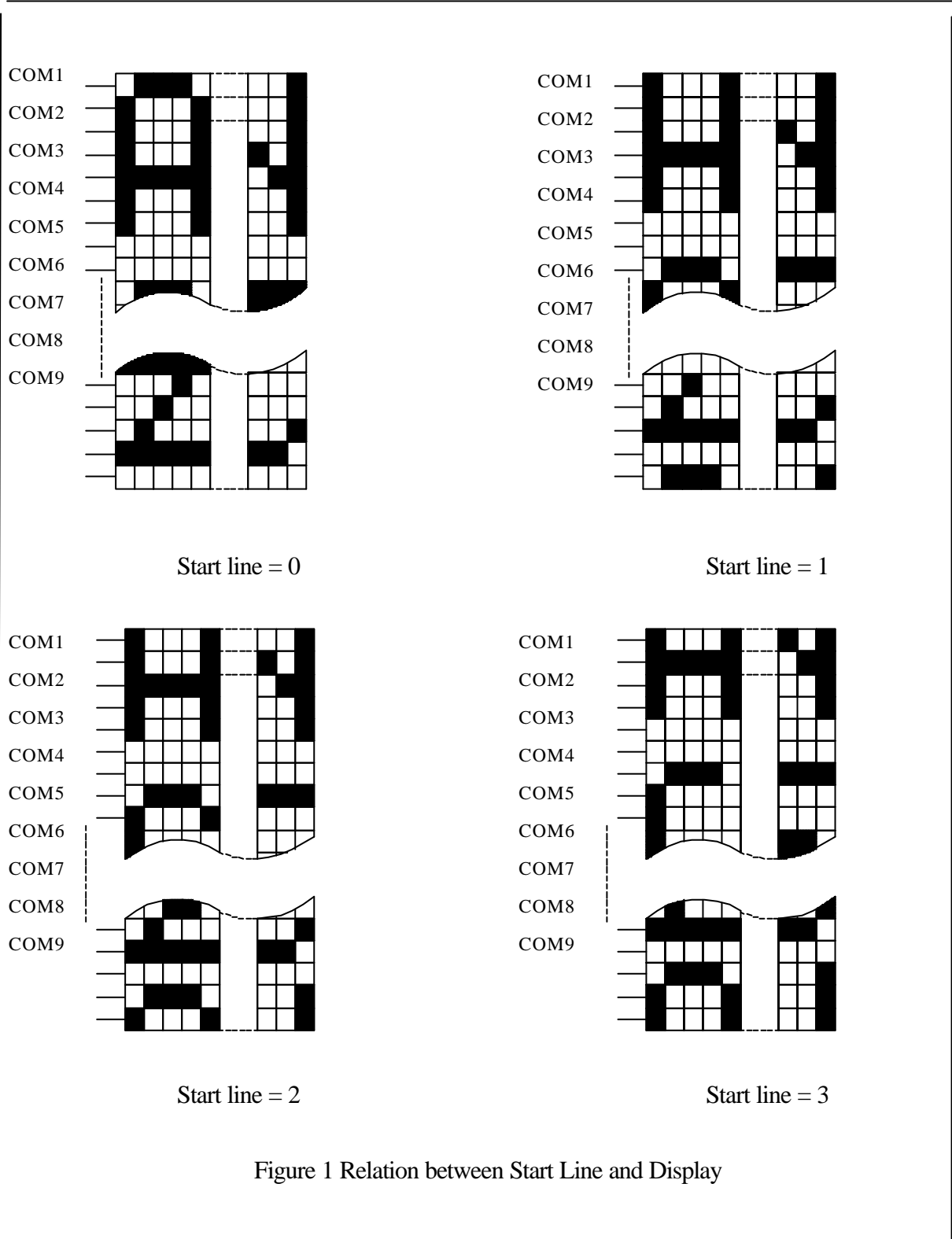

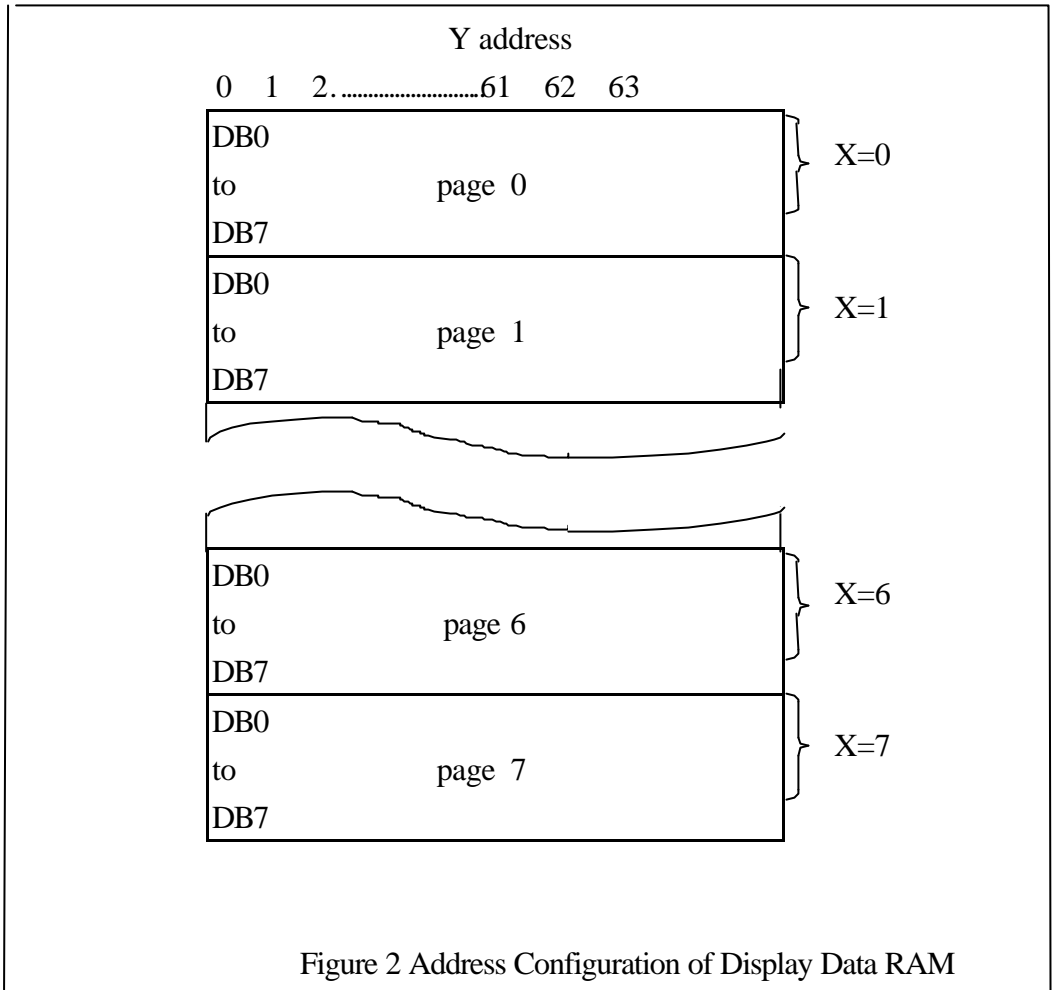

Note: “128*64” consist of 2 “64*64”

CS1⇒ Chip enable for left 64*64 (segment1 to segment 64)

CS2⇒ Chip enable for right 64*64 (segment 65 to segment 128)

3. QUALITY ASSURANCE SYSTEM

3.1 Quality Assurance Flow Chart

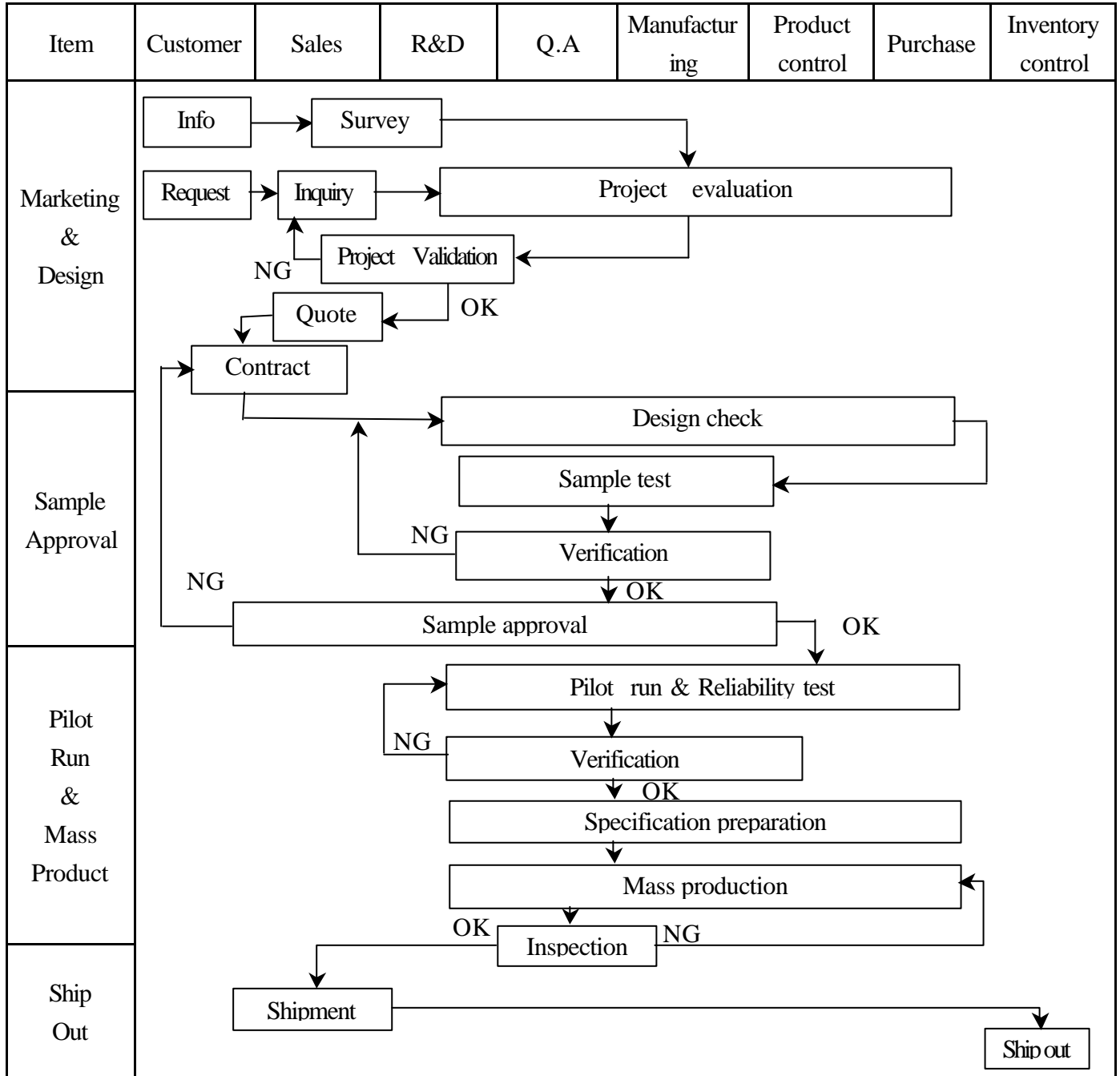

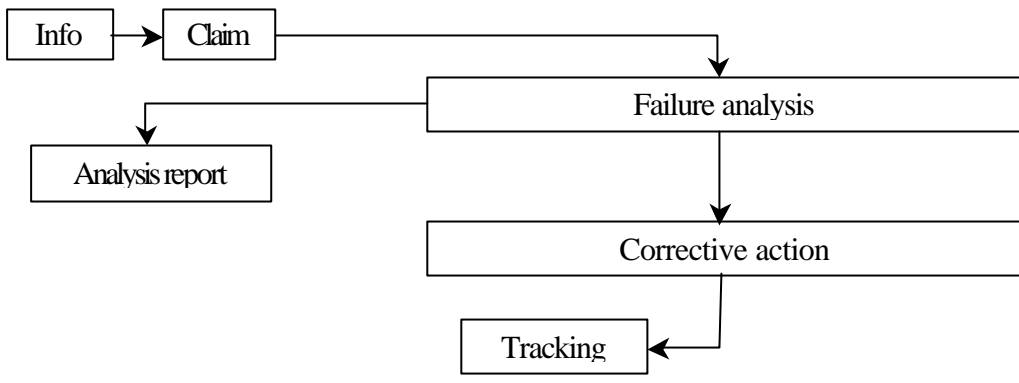
Item	Customer	Sales	R&D	Q.A	Manufacturing	Product control	Purchase	Inventory control
Sales Service	 <pre> graph TD Info[Info] --> Claim[Claim] Claim --> Failure[Failure analysis] Claim --> Report[Analysis report] Failure --> Action[Corrective action] Action --> Tracking[Tracking] </pre>							
Q.A Activity	<ol style="list-style-type: none"> 1. ISO 9001 Maintenance Activities 2. Process improvement proposal 3. Equipment calibration 4. Education And Training Activities 5. Standardization Management 							

3.2 Inspection Specification

Inspection Standard : MIL-STD-105E Table Normal Inspection Single Sampling Level .

Equipment : Gauge, MIL-STD, Powertip Tester, Sample.

IQC Defect Level : Major Defect AQL 0.4; Minor Defect AQL 1.5.

FQC Defect Level : 100% Inspection.

OUT Going Defect Level : Sampling.

Specification :

NO	Item	Specification	Judge	Level
1	Part Number	The part number is inconsistent with work order of production	N.G.	Major
2	Quantity	The quantity is inconsistent with work order of production	N.G.	Major
3	Electronic characteristics of LCM $A = (L + W) \div 2$	The display lacks of some patterns.	N.G.	Major
		Missing line.	N.G.	Major
		The size of missing dot, A is $> 1/2$ Dot size	N.G.	Major
		There is no function.	N.G.	Major
		Output data is error	N.G.	Major
4	Appearance of LCD $A = (L + W) \div 2$ Dirty particle (Including scratch, bubble)	Material is different with work order of production	N.G.	Major
		LCD is assembled in inverse direction	N.G.	Major
		Bezel is assembled in inverse direction	N.G.	Major
		Shadow is within LCD viewing area + 0.5 mm	N.G.	Major
		The diameter of dirty particle, A is > 0.4 mm	N.G.	Minor
		Dirty particle length is > 3.0 mm, and 0.01 mm $<$ width 0.05mm	N.G.	Minor
		Display is without protective film	N.G.	Minor
		Conductive rubber is over bezel 1mm	N.G.	Minor
		Polarizer exceeds over viewing area of LCD	N.G.	Minor
		Area of bubble in polarizer, A > 1.0 mm, the number of bubble is > 1 piece.	N.G.	Minor
		0.4 mm $<$ Area of bubble in polarizer, A < 1.0 mm, the number of bubble is > 4 pieces.	N.G.	Minor
5	Appearance of PCB $A = (L + W) \div 2$	Burned area or wrong part number is on PCB	N.G.	Major
		The symbol, character, and mark of PCB are unidentifiable.	N.G.	Minor
		The stripped solder mask , A is > 1.0 mm	N.G.	Minor
		0.3 mm $<$ stripped solder mask or visible circuit, A < 1.0 mm, and the number is 4 pieces	N.G.	Minor
		There is particle between the circuits in solder mask	N.G.	Minor
		The circuit is peeled off or cracked	N.G.	Minor
		There is any circuits risen or exposed.	N.G.	Minor
		0.2 mm $<$ Area of solder ball, A is 0.4mm	N.G.	Minor
		The number of solder ball is 3 pieces	N.G.	Minor
The magnitude of solder ball, A is > 0.4 mm.	N.G.	Minor		

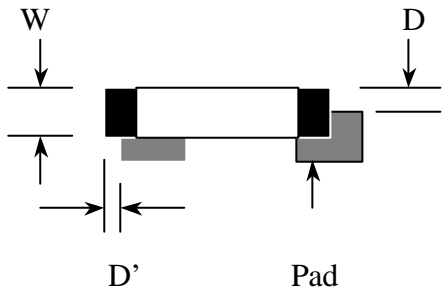
NO	Item	Specification	Judge	Level
6	Appearance of molding $A=(L+W) \div 2$	The shape of modeling is deformed by touching.	N.G.	Major
		Insufficient epoxy: Circuit or pad of IC is visible	N.G.	Minor
		Excessive epoxy: Diameter of modeling is $> 20\text{mm}$ or height is $> 2.5\text{mm}$	N.G.	Minor
		The diameter of pinhole in modeling, A is $> 0.2\text{mm}$.	N.G.	Minor
7	Appearance of frame $A=(L+W) \div 2$	The folding angle of frame must be $> 45^\circ +10^\circ$	N.G.	Minor
		The area of stripped electroplate in top-view of frame, A is $> 1.0\text{mm}$.	N.G.	Minor
		Rust or crack is (Top view only)	N.G.	Minor
		The scratched width of frame is $> 0.06\text{mm}$. (Top view only)	N.G.	Minor
8	Electrical characteristic of backlight $A=(L+W) \div 2$	The color of backlight is nonconforming	N.G.	Major
		Backlight can't work normally.	N.G.	Major
		The LED lamp can't work normally	N.G.	Major
		The unsoldering area of pin for backlight, A is $> 1/2$ solder joint area.	N.G.	Minor
		The height of solder pin for backlight is $> 2.0\text{mm}$	N.G.	Minor
10	Assembly parts $A=(L+W) \div 2$	The mark or polarity of component is unidentifiable.	N.G.	Minor
		The height between bottom of component and surface of the PCB is floating $> 0.7\text{mm}$	N.G.	Minor
		$D > 1/4W$ 	N.G.	Minor
		End solder joint width, D' is $> 50\%$ width of component termination or width of pad	N.G.	Minor
		Side overhang, D is $> 25\%$ width of component termination.	N.G.	Minor
		Component is cracked, deformed, and burned, etc.	N.G.	Minor
		The polarity of component is placed in inverse direction.	N.G.	Minor
		Maximum fillet height of solder extends onto the component body or minimum fillet height is $< 0.5\text{mm}$.	N.G.	Minor

4. RELIABILITY TEST

4.1 Reliability Test Condition

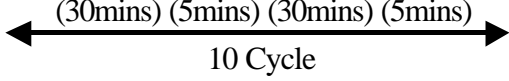
NO	Item	Test Condition	
1	High Temperature Storage	Storage at 80 ± 2 °C 96~100 hrs Surrounding temperature, then storage at normal condition 4hrs	
2	Low Temperature Storage	Storage at -30 ± 2 °C 96~100 hrs Surrounding temperature, then storage at normal condition 4hrs	
3	High Temperature /Humidity Storage	1.Storage 96~100 hrs 60 ± 2 °C, 90~95%RH surrounding temperature, then storage at normal condition 4hrs. (Excluding the polarizer). or 2.Storage 96~100 hrs 40 ± 2 °C, 90~95%RH surrounding temperature, then storage at normal condition 4 hrs.	
4	Temperature Cycling	<div style="text-align: center;"> -20 25 70 25 (30mins) (5mins) (30mins) (5mins)  </div>	
5	Vibration	10~55Hz (1 minute) 1.5mm X,Y and Z direction * (each 2hrs)	
6	ESD Test	Air Discharge: Apply 6 KV with 5 times discharge for each polarity +/-	Contact Discharge: Apply 250V with 5 times discharge for each polarity +/-
		Testing location: Around the face of LCD	Testing location: 1.Apply to bezel. 2.Apply to Vdd, Vss.
7	Drop Test	Packing Weight (Kg)	Drop Height (cm)
		0 ~ 45.4	122
		45.4 ~ 90.8	76
		90.8 ~ 454	61
		Over 454	46

5. PRECAUTION RELATING PRODUCT HANDLING

5.1 SAFETY

- 5.1.1 If the LCD panel breaks , be careful not to get the liquid crystal to touch your skin.
- 5.1.2 If the liquid crystal touches your skin or clothes , please wash it off immediately by using soap and water.

5.2 HANDLING

- 5.2.1 Avoid any strong mechanical shock which can break the glass.
- 5.2.2 Avoid static electricity which can damage the CMOS LSI—When working with the module , be sure to ground your body and any electrical equipment you may be using.
- 5.2.3 Do not remove the panel or frame from the module.
- 5.2.4 The polarizing plate of the display is very fragile. So , please handle it very carefully ,do not touch , push or rub the exposed polarizing with anything harder than an HB pencil lead (glass , tweezers , etc.)
- 5.2.5 Do not wipe the polarizing plate with a dry cloth , as it may easily scratch the surface of plate.
- 5.2.6 Do not touch the display area with bare hands , this will stain the display area.
- 5.2.7 Do not use ketonics solvent & aromatic solvent. Use with a soft cloth soaked with a cleaning naphtha solvent.

5.3 STORAGE

- 5.3.1 Store the panel or module in a dark place where the temperature is 25 ± 5 and the humidity is below 65% RH.
- 5.3.2 Do not place the module near organics solvents or corrosive gases.
- 5.3.3 Do not crush , shake , or jolt the module.

5.4 TERMS OF WARRANTY

- 5.4.1 Applicable warrant period
The period is within thirteen months since the date of shipping out under normal using and storage conditions.
- 5.4.2 Unaccepted responsibility
This product has been manufactured to your company' s specification as a part for use in your company' s general electronic products. It is guaranteed to perform according to delivery specifications. For any other use apart from general electronic equipment , we cannot take responsibility if the product is used in nuclear power control equipment , aerospace equipment , fire and security systems or any other applications in which there is a direct risk to human life and where extremely high levels of reliability are required.